

(No Model.)

3 Sheets—Sheet 1.

C. F. E. PETERLEIN. BACK KNIFE GAGE LATHE.

No. 474,856.

Patented May 17, 1892.

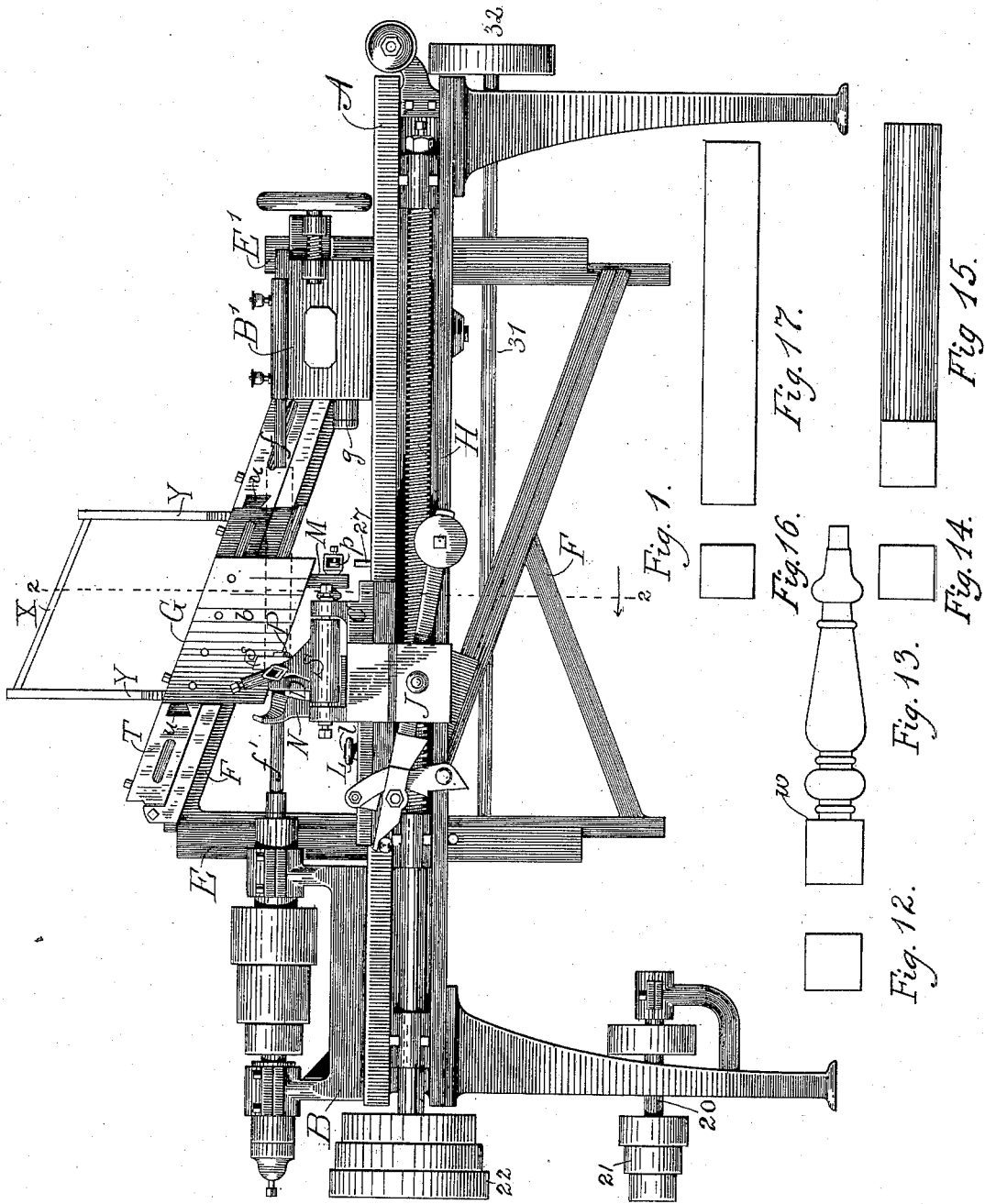

WITNESSES:
H. E. Johnson
Charles E. Mell.

INVENTOR
C. F. Edward Peterlein
 BY *Brown and Shaw*
 ATTORNEYS

(No Model.)

3 Sheets—Sheet 2.

C. F. E. PETERLEIN.
BACK KNIFE GAGE LATHE.

No. 474,856.

Patented May 17, 1892.

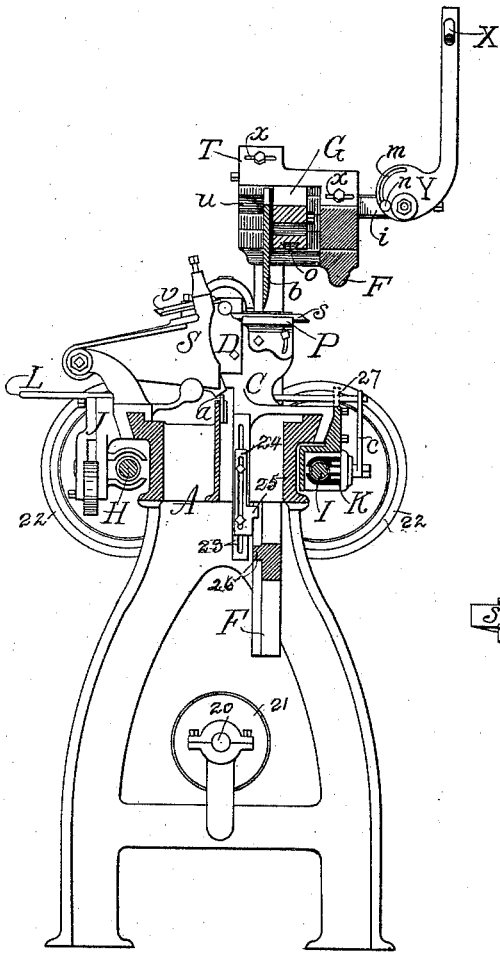

Fig. 2.

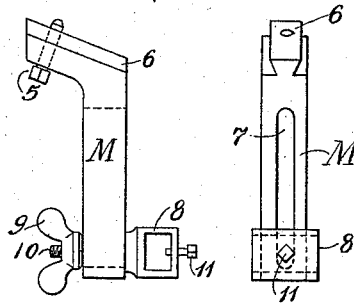

Fig. 3. Fig. 4

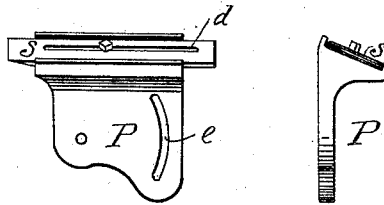

Fig. 5. Fig. 6.

WITNESSES:

H. Johnson
Charles E. Smell,

INVENTOR

C. F. Edward Peterlein.

BY *Brown and Shaw*
his ATTORNEYS

(No Model.)

C. F. E. PETERLEIN.
BACK KNIFE GAGE LATHE.

3 Sheets—Sheet 3.

No. 474,856.

Patented May 17, 1892.

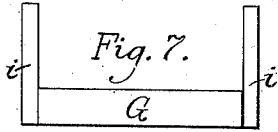

Fig. 7.

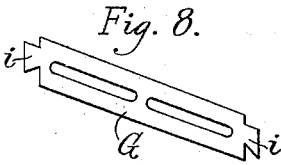

Fig. 8.

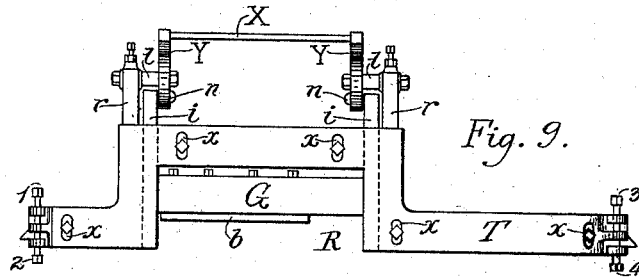

Fig. 9.

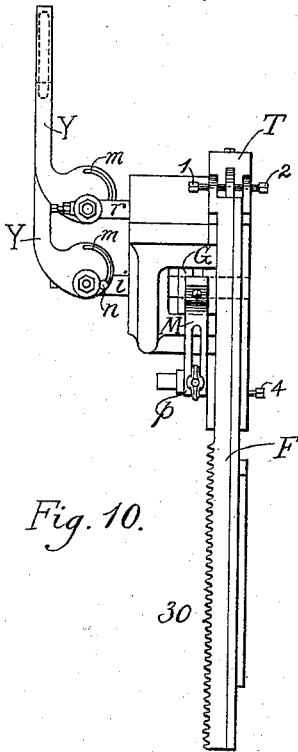

Fig. 10.

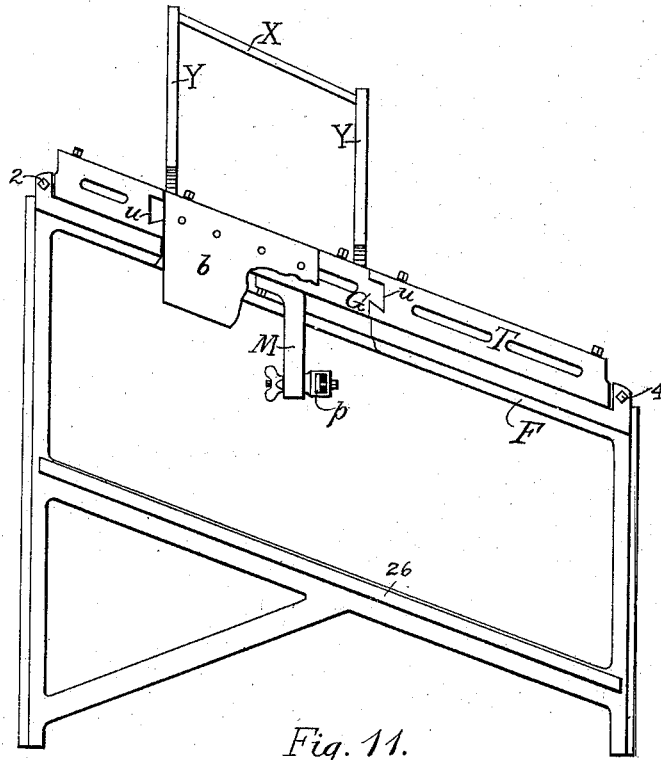

Fig. 11.

WITNESSES:

H. Johnson
Charles E. Smith

INVENTOR

C. F. Edward Peterlein.

BY *Brown and Shaw*
ATTORNEYS

UNITED STATES PATENT OFFICE.

CHARLES FRED EDWARD PETERLEIN, OF BINGHAMTON, NEW YORK.

BACK-KNIFE GAGE-LATHE.

SPECIFICATION forming part of Letters Patent No. 474,856, dated May 17, 1892.

Application filed November 3, 1890. Serial No. 370,224. (No model.)

To all whom it may concern:

Be it known that I, CHARLES FRED EDWARD PETERLEIN, of Binghamton, in the county of Broome and State of New York, have invented certain new and useful Improvements in Back-Knife Gage-Lathes, of which the following is a specification.

This invention relates to improvements on the ordinary back-knife gage-lathes—such as are, for example, made and sold by the S. C. Forsaith Machine Company, of Manchester, New Hampshire. Similar well-known back-knife gage-lathes are shown and described in Letters Patent of the United States to Baxter D. Whitney, No. 29,534, dated August 7, 1860, and to Loring Atwood and Edward Ripley, No. 99,810, dated February 15, 1870.

The object of the present invention is to so modify the construction and action of the ordinary back-knife gage-lathe as to enable a square shoulder to be cut upon turned work. The improvements which enable this to be done constitute the invention, are applicable to any back-knife gage-lathe, and in no way interfere with the operation of the lathe in the usual manner.

The invention consists in the following alterations of and attachments to the back-knife gage-lathes in ordinary use. The sliding rest or cutting-tool carriage is provided with both a forward and back feed, so that it is fed positively both forward and back. In addition to the usual die or sizing-ring, the usual rest for the sizing or scoring knife or cutter located forward of the die or sizing-ring, and the usual roughing knife or cutter holder hinged to the cutter-carriage, so as to follow the pattern placed near the center of the lathe-bed in the line of the spindles, the cutter-carriage is provided with a rest for a second sizing or scoring knife or cutter, which is located back of the die or sizing-ring and on the opposite side of the axis of the work-holding spindles, the purpose of this second sizing or scoring knife or cutter being to turn or size the stock to the proper cylindrical form to fit the die or sizing-ring during the backward travel of the carriage. The ordinary back-knife frame of the lathe is fitted with a back-knife section, which is movable away from the work or stock, so that the back-knife need not operate upon the stock or work dur-

ing the backward travel of the carriage, and this movable section carries the parting-tool, which forms the square shoulder on the work or stock.

The improvements are illustrated in the accompanying drawings, wherein—

Figure 1 is a front elevation of the lathe. Fig. 2 is a vertical section thereof in a plane indicated by the line 2 2 in Fig. 1. Fig. 3 is a front view, and Fig. 4 a side view, of the parting-tool holder in detail. Fig. 5 is a side view, and Fig. 6 an edge view, of the scoring or sizing cutter which acts on the stock during the backward movement of the carriage and of the rest or holder therefor. Fig. 7 is a plan view, and Fig. 8 a front edge view, of the movable back-knife-holding section detached. Fig. 9 is a plan view, Fig. 10 a side view, and Fig. 11 a front view, of the back-knife frame removed from the lathe. Figs. 12 and 13 are end and side views, respectively, of a completed chair-leg such as the machine is adapted to make. Figs. 14 and 15 are end and side views, respectively, of the stock after it has been reduced by the sizing or scoring knife. Figs. 16 and 17 are end and side views, respectively, of the stock such as is put into the machine.

A is the bed of the lathe, which may be of any material and of any general construction adapted for the purpose.

B is the usual head-stock carrying the usual head-spindle f' , which is rotated in any usual manner, as from the drive-shaft 20 and the speed-pulleys 21 22, and B' is the usual tail-stock, carrying the usual tail-spindle f .

C is the sliding rest or carriage for the cutters and for the sizing-ring or die, and it is moved forward and back on the bed of the lathe parallel with the axis of the spindles $f f'$. The backward movement of the carriage is limited by a stationary buffer g in the path of the carriage. Its forward movement toward the head-stock B is effected by means of a rotating feed-screw H, which is journaled to the lathe-bed at one side and is rotated in the usual manner. This feed-screw extends through an extension of the carriage, and is adapted to be engaged therewith or disengaged therefrom by means of a coupling device J of well-known character and operation. The backward movement of the car-

riage is effected in a similar manner by a second rotating feed-screw I on the opposite side of the lathe-bed, which is adapted to be disengaged from and engaged with the carriage 5 by a coupler K, having a similar construction and operation to the coupler J and which is arranged to be actuated from the front of the lathe by means of a vertical arm *c* and a horizontal lever L, which is pivotally connected 10 to the arm *c* and at *l* to the carriage.

The two couplers J K may be of any well-known construction such as are usual in the art. No novelty is claimed in these couplers.

The carriage C is equipped with the usual 15 sizing-ring or die D, the sizing or scoring knife or cutter N forward of the die, and the swinging rest or holder S, which follows the pattern-gage *a* and which carries the roughing cutter or knife *v*, all of which parts are or 20 may be of usual and known construction and operation. The swinging rest or holder S not only permits the cutter *v* to follow the pattern *a*, but also permits it to be swung back entirely out of action. The cutter *v* is thus 25 a pivotally-mounted cutter. In addition to these usual appliances the carriage also carries a tool-holder P for the sizing or scoring knife or cutter *s*, which rounds the stock during the backward movement of the carriage. 30 This holder P and knife *s* are on the side of the axis of the spindles *f f'*, opposite to that on which the die D and cutters N *v* are located, and the cutter *s* is back of the die. The holder P is pivoted to the carriage C so 35 as to be adjustable thereon in a vertical plane, and it is maintained in any desired position by means of a set-screw co-operating with a curved slot *e*, concentric with the pivot of the holder P. (See Figs. 2 and 5.) The knife 40 or cutter *s* is also adjustable on the holder P to and away from the work or stock by means of a set-screw and slot *d*. The knife or cutter *s* is thus adjustable both angularly and to 45 and from the stock. The object of the cutter *s* is to turn the work or stock to a cylindrical form, as shown in Fig. 15, during the backward travel of the carriage. When cutter *s* is used for this purpose, cutter N is not used, and vice versa, if the lathe is used in the 50 manner of ordinary gage-lathes.

F is the back-knife frame, which slides vertically in vertical guides E E' in the usual manner, its movement being controlled by connection with the sliding carriage C. The 55 connection between the carriage C and frame F, whereby the vertical movement of the frame is controlled by the carriage as the latter reciprocates, is of any old and well-known character, the construction in this respect constituting no part of the present improvements. I have shown in the drawings one of the well-known arrangements. The frame F is caused 60 to descend as the carriage moves from tail-stock B' to head-stock B by means shown in Fig. 2. Carried by the carriage C is a depending bracket 23, having a vertically-adjustable bar 24, which carries a stud 25, that engages

an inclined flange 26 of the frame F. The means for effecting the upward movement of the frame F when the carriage C moves in the opposite direction are also partly indicated. 7 The frame F has a vertical rack 30, (see Fig. 10,) which engages a pinion (not shown) on the end of a shaft 31, which is journaled beneath the bed of the lathe. (See Fig. 1.) 7 This shaft 31 carries on its outer end a band-wheel 32, to which is attached one end of a strap which passes partly around the wheel 32 and carries a weight at its other end. This weight tends to rotate the shaft 31 in the 8 proper direction to elevate the frame F. I have not considered it necessary to illustrate the weight and strap or the pinion between the shaft 31 and rack 30, since this frame-raising device is a well-known one in the art 8 and constitutes no part of the present invention.

In order to provide room for the unturned stock to be placed in position between the spindles without interference with the back-knife when the carriage is at the head-stock B, (and the back-knife frame is consequently down,) the back-knife frame is provided with a recess R, (see Fig. 9,) and the back-knife is laterally adjustable by means of said recess. 9 Upon the top of the back-knife frame F is fastened (by means of cap-screws and slots *axx*) the knife-bar T, which is rendered adjustable transversely by means of the set-screws 1, 2, 3, and 4. Upon the sides and extending through the back of a recess formed in the bar T to correspond with the recess R in the frame F are guideways *u u*, in which are fitted and slide the guide-flanges *i i* of the transversely-movable back-knife section G, which carries the back-knife *b* of any desired contour or design. Upon its under side the section G is provided with a longitudinal guideway *o*, extending in a vertical plane parallel with the axis of the spindles *f f'*, which guideway *o* receives and holds the guide-flange 6 of the parting-tool post M, the post M being adjustable in said groove and locked therein in any desired position by a set-screw 5. (See Figs. 3 and 4.) The parting-tool or cutter *p* (see Figs. 1 and 11) is carried directly by a holder or strap 8, in which it is adjustable laterally to and from the stock and in which it is locked in any desired position by means of a set-screw 11. The holder or strap 8 is vertically adjustable by means of a threaded shank 10, extending through a vertical slot 7 in the post M, and is locked in any desired vertical position by means of the thumb-screw *g*. The parting-tool or cutter *p*, which cuts the square shoulder on the stock, (see *w*; Fig. 13,) is thus laterally, vertically, and longitudinally adjustable—laterally by reason of the holder 8 and set-screw 11, vertically by reason of the shank 10, slot 7, and set-screw 9, and longitudinally by reason of the flange 6, groove *o*, and set-screw 5. The parting-tool or cutter *p* is also movable to and from the stock by the movement laterally of the section G.

The section G is laterally movable to and from the stock by the following means: The guide-flanges *ii* of the section G extend back of the bar T and are provided with projecting pins *nn*, extending therethrough, which enter cam-slots *mm*, respectively, in eccentric cam-plates Y Y, the lever-arms of which are joined together by a bar X and are pivoted, respectively, on shouldered axles *tt*, bolted to rearwardly-extending brackets *rr* on the bar T. By turning the cam-plates Y Y by means of the handle-bar X the cam-slots *mm* act to move the section G (and with it the back-knife *b* and parting-tool *p*) to and from the stock.

The operation of the machine is as follows: The stick to be turned is first planed and cut to the desired size, as shown in Figs. 16 and 17. The carriage C is then drawn to the head end of the lathe—that is, toward the head-stock B—thereby drawing down the back-knife frame F by means of the usual connections between the carriage and back-knife frame. The section G and with it the back knife *b* and shoulder-cutting parting-tool *p* are drawn back away from the axis of the spindles by means of the handle X and cam plates or levers Y Y, and the rest S, carrying the tool *v*, is swung back to render said tool *v* inoperative. The stock is then placed in position between the spindles *ff'*. Then by means of the lever L the carriage C is coupled with the back-feed screw I, which feeds the carriage backward to the tail-stock B'. As the carriage travels back the sizing or scoring cutter *s* turns the stick to a cylindrical shape and to a diameter to nicely fit the supporting-die or sizing-ring D from the head end of the stick to the point at which the shoulder *w* is to be formed. At this point the feed of the carriage C is automatically stopped by the lever L encountering a fixed stop 27, carried by the bed A of the lathe, (see Figs. 1 and 2,) and thereby uncoupling the carriage from the back-feed screw I. It will be noted that in Fig. 2 the stop 27 is indicated in dotted lines only. This is due to the fact that the plane of the section of Fig. 2, as indicated by the line 2 2 in Fig. 1, passes in front of the stop 27, so that the stop should not actually appear in Fig. 2. In order, however, that the lateral position of the stop 27 on the lathe-bed may be indicated, the stop is shown in dotted lines in Fig. 2. The stick is then turned to the shape shown in Fig. 15. At this juncture by means of the lever-cams Y Y the section G, carrying the back-knife *b* and the parting-tool or shoulder-cutter *p*, (which have been elevated to bring the cutter *p* into the plane of the stick by the well-known connections between the carriage C and back-knife frame F,) is drawn forward and the tool or cutter *p* is thus fed up to the stick at the desired point and the square shoulder is cut as desired. The section G is now in line with the front edge of the remainder of the back-knife bar

T, and the back-knife *b* is in proper operative position. The stick is then finished from the shoulder *w* forward in the usual manner. The carriage C is coupled to the forward feed-screw H, and during the forward feed the roughing knife or cutter *v*, which is first brought into operative position by the swinging rest S, brings the stick approximately to the desired shape, while the back-knife *b* finishes the stick. The completed article is indicated in Figs. 12 and 13.

It is evident that the lathe can be used as an ordinary back-knife lathe by removing the cutters *s* and *p*, retaining section G in its forward position, and by using the forwardly-acting sizing or scoring cutter N.

The movement of the back-knife section G to and from the stock need not necessarily be in a horizontal direction. It is sufficient that the back-knife should be movable to and from the stock.

I claim as my invention—

1. In a back-knife gage-lathe, a traveling carriage, two feed-screws which move said carriage forward and back, respectively, a sizing or scoring cutter mounted on said carriage in position to operate on the stock during the backward travel of the carriage, and a roughing-cutter pivotally connected to said carriage so that it may be brought into position to operate on the stock during the forward travel of the carriage, in combination with a back-knife frame movable vertically, a back-knife section carrying the back-knife, which is movable to and from the stock, said back-knife operating upon the stock during the forward movement of the carriage, and a parting-tool for cutting a square shoulder on the stock, which is carried by said back-knife frame and is movable thereon to and from the stock, substantially as set forth.

2. In a lathe, the spindles between which the stock is mounted, the traveling carriage which moves parallel with the axis of said spindles, the feed-screws which move said carriage forward and back, respectively, and means for coupling said carriage to said screws, respectively, in combination with the pattern, the roughing-cutter, which is carried by the carriage, being pivotally mounted thereon, and which follows said pattern, said roughing-cutter being located at one side of the axis of said spindles, and said roughing-cutter operating on the stock during the forward travel of the carriage, and a sizing or scoring cutter, which is carried by the carriage, located on the side of the axis of the spindles opposite to that on which the said roughing-cutter is located, so that it operates on the stock during the backward travel of the carriage, substantially as set forth.

3. In a lathe, the spindles between which the stock is mounted, the carriage, the two feed-screws which move said carriage back and forth, means for coupling said carriage to said screws, respectively, the pattern, the rough-

ing-cutter carried by the carriage being pivotally mounted thereon, which follows said pattern and operates on the stock during the forward travel of the carriage, the die or sizing-ring, and the forward-feed sizing or scoring cutter which is located on the carriage forward of the die or sizing-ring so as to operate on the stock during the forward travel of the carriage, in combination with the backward-feed sizing or scoring cutter which is located on the carriage back of the die or sizing-ring and on the side of the axis of the spindles opposite to that on which the forward-feed sizing or scoring cutter is located, said backward-feed sizing or scoring cutter operating on the stock during the backward travel of the carriage, each of said two sizing or scoring cutters being unused and idle when the other is used, substantially as set forth.

4. In a back-knife gage-lathe, the vertically-movable back-knife frame, in combination with a movable back-knife section carrying the back-knife, which section is movable laterally on said frame to and from the stock, substantially as set forth.

5. In a back-knife gage-lathe, the back-knife frame, in combination with the parting-tool *p*, carried by said frame, for cutting a square shoulder on the stock, substantially as set forth.

6. In a back-knife gage-lathe, the back-knife frame, in combination with the parting-tool *p*, carried by said frame, for cutting a square shoulder on the stock, said tool being movable to and from the stock, substantially as set forth.

7. In a back-knife gage-lathe, the back-knife frame, in combination with the parting-tool *p*, which is carried by said frame and

which is adjustable laterally, longitudinally, and vertically, substantially as set forth.

8. In a back-knife gage-lathe, the back-knife frame and section *G*, carrying the back-knife *b*, said section being movable laterally and said section having longitudinal groove *o*, in combination with the post *M*, having guide-flange *6*, fitting and movable in said groove *o*, set-screw *5* for locking said post *M* in said groove, said post *M* having also vertical groove *7*, the holder or strap *8*, having threaded stem *10* located in said groove *7* and vertically-movable therein, the thumb-screw *9*, locking said holder or strap to said post *M*, and the tool *p*, movable laterally in said holder or strap *8*, and the set-screw *11* for locking said tool to said holder or strap, substantially as set forth.

9. The back-knife frame and the movable section *G*, carrying the back-knife, in combination with the lever and cam mechanism *X Y Y* for operating said section *G*, substantially as set forth.

10. The back-knife frame having guide-ways *u u* and brackets *r r* and the movable section *G*, carrying the back-knife and having guide-flanges *i i* sliding in said grooves *u u*, said flanges carrying pins *n n*, in combination with the lever cam-plates *Y Y*, pivoted to said brackets *r r* and having cam-slots *m m* engaging, respectively, with said pins *n n*, and the bar *X*, connecting said lever-plates *Y Y*, substantially as set forth.

In witness whereof I have hereunto signed my name in the presence of two subscribing witnesses.

CHARLES FRED EDWARD PETERLEIN.

Witnesses:

EDWARD K. CLARK,
EDWARD M. FITZGERALD.